

Poulan PRO



OWNER'S MANUAL

MODEL NUMBER:
PR621
SNOW THROWER

⚠ WARNING:
Read the Owner's Manual and follow all Warnings and Safety Instructions. Failure to do so can result in serious injury.

Always Wear Eye Protection During Operation

436414 Rev 4 09.01.10 TH
Printed in the U.S.A.

CONGRATULATIONS on your purchase of a new snow thrower. It has been designed, engineered and manufactured to give best possible dependability and performance.

Should you experience any problem you cannot easily remedy, please contact your nearest authorized service center. We have competent, well-trained technicians and the proper tools to service or repair this unit.

Please read and retain this manual. The instructions will enable you to assemble and maintain your snow thrower properly. Always observe the "SAFETY RULES".

Safe Operation Practices for Walk-Behind Snow Throwers

IMPORTANT: This snow thrower is capable of amputating hands and feet and throwing objects. Failure to observe the following safety instructions could result in serious injury.



Look for this symbol  to point out important safety precautions. It means **CAUTION!!! BECOME ALERT!!! YOUR SAFETY IS INVOLVED.**



WARNING: Always disconnect spark plug wire and place it where it cannot contact plug in order to prevent accidental starting when setting up, transporting, adjusting or making repairs.



WARNING: This snow thrower is for use on sidewalks, driveways and other ground level surfaces. Caution should be exercised while using on sloping surfaces. Do not use snow thrower on surfaces above ground level such as roofs of residences, garages, porches or other such structures or buildings.



WARNING: Snow throwers have exposed rotating parts, which can cause severe injury from contact, or from material thrown from the discharge chute. Keep the area of operation clear of all persons, small children and pets at all times including startup.



CAUTION: Muffler and other engine parts become extremely hot during operation and remain hot after engine has stopped. To avoid severe burns on contact, stay away from these areas.



WARNING: Engine exhaust, some of its constituents, and certain vehicle components contain or emit chemicals known to the State of California to cause cancer and birth defects or other reproductive harm.

Training

1. Read, understand and follow all instructions on the machine and in the manual(s) before operating this unit. Be thoroughly familiar with the controls and the proper use of the equipment. Know how to stop the unit and disengage the controls quickly.
2. Never allow children to operate the equipment. Never allow adults to operate the equipment without proper instruction.
3. Keep the area of operation clear of all persons, particularly small children.
4. Exercise caution to avoid slipping or falling, especially when operating the snow thrower in reverse.

Preparation

1. Thoroughly inspect the area where the equipment is to be used and remove all doormats, sleds, boards, wires, and other foreign objects.
2. Disengage all clutches and shift into neutral before starting the engine (motor) if equipped.
3. Do not operate the equipment without wearing adequate winter garments. Avoid loose fitting clothing that can get caught in moving parts. Wear footwear that will improve footing on slippery surfaces.
4. Handle fuel with care; it is highly flammable
 - (a) Use an approved fuel container.
 - (b) Never add fuel to a running engine or hot engine.
 - (c) Fill fuel tank outdoors with extreme care. Never fill fuel tank indoors.

- (d) Never fill containers inside a vehicle or on a truck or trailer bed with a plastic liner. Always place containers on the ground, away from your vehicle, before filling.
 - (e) When practical, remove gas-powered equipment from the truck or trailer and refuel it on the ground. If this is not possible, then refuel such equipment on a trailer with a portable container, rather than from a gasoline dispenser nozzle.
 - (f) Keep the nozzle in contact with the rim of the fuel tank or container opening at all times, until refueling is complete. Do not use a nozzle lock-open device.
 - (g) Replace gasoline cap securely and wipe up spilled fuel.
 - (h) If fuel is spilled on clothing, change clothing immediately.
5. Use extension cords and receptacles as specified by the manufacturer for all units with electric drive motors or electric starting motors.
 6. Never attempt to make any adjustments while the engine (motor) is running (except when specifically recommended by manufacturer).
 7. Always wear safety glasses or eye shields during operation or while performing an adjustment or repair to protect eyes from foreign objects that may be thrown from the machine.

Operation

1. Do not put hands or feet near or under rotating parts. Keep clear of the discharge opening at all times.

2. Exercise extreme caution when operating on or crossing gravel drives, walks, or roads. Stay alert for hidden hazards or traffic.
3. After striking a foreign object, stop the engine (motor), disconnect the cord on electric motors, thoroughly inspect the snow thrower for any damage, and repair the damage before restarting and operating the snow thrower. Remove key.
4. If the unit should start to vibrate abnormally, stop the engine (motor) and check immediately for the cause. Vibration is generally a warning of trouble.
5. Stop the engine (motor) whenever you leave the operating position, before unclogging the auger housing or discharge chute, and when making any repairs, adjustments or inspections.
6. When cleaning, repairing or inspecting the snow thrower, stop the engine and make certain the auger blades and all moving parts have stopped. Remove key.
7. Do not run the engine indoors, except when starting the engine and for transporting the snow thrower in or out of the building. Open the outside doors; exhaust fumes are dangerous.
8. Exercise extreme caution when operating on slopes.
9. Never operate the snow thrower without proper guards, and other safety protective devices in place and working.
10. Never direct the discharge toward people or areas where property damage can occur. Keep children and others away.
11. Do not overload the machine capacity by attempting to clear snow at too fast a rate.
12. Never operate the machine at high transport speeds on slippery surfaces. Look behind and use care when operating in reverse.
13. Disengage power to the auger blades when snow thrower is transported or not in use.
14. Use only attachments and accessories approved by the manufacturer of the snow thrower.
15. Never operate the snow thrower without good visibility or light. Always be sure of your footing, and keep a firm hold on the handles. Walk; never run.
16. Never touch a hot engine or muffler.

Clearing a Clogged Discharge Chute



Hand contact with the rotating auger blades inside the discharge chute is the most common cause of injury associated with snow throwers. Never use your hand to clean out the discharge chute.

To clear the chute:

1. SHUT THE ENGINE OFF!
2. Wait 10 seconds to be sure the auger blades have stopped rotating.
3. Always use a clearing tool at least 15 inches long.

Maintenance and Storage

1. Check shear bolts and other bolts at frequent intervals for proper tightness to be sure the equipment is in safe working condition.
2. Never store the machine with fuel in the fuel tank inside a building where ignition sources are present such as hot water heaters, space heaters, or clothes dryers. Allow the engine to cool before storing in any enclosure.
3. Always refer to operator's manual for important details if the snow thrower is to be stored for an extended period.
4. Maintain or replace safety and instruction labels, as necessary.
5. Run the machine a few minutes after throwing snow to prevent freeze-up of the collector/impeller.

SERIAL NUMBER: _____

DATE OF PURCHASE: _____

THE MODEL AND SERIAL NUMBERS WILL BE FOUND ON A DECAL ATTACHED TO THE REAR OF THE SNOW THROWER HOUSING (Figure 1).

YOU SHOULD RECORD BOTH SERIAL NUMBER AND DATE OF PURCHASE AND KEEP IN A SAFE PLACE FOR FUTURE REFERENCE.

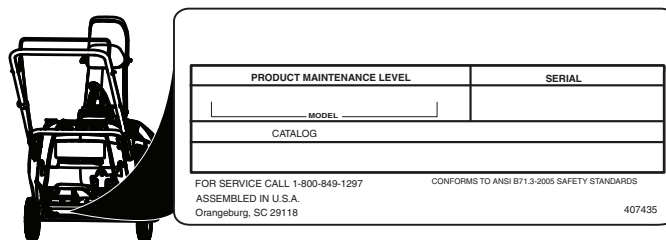

Figure 1

CUSTOMER RESPONSIBILITIES

- Read and observe the safety rules.
- Follow a regular schedule in maintaining, caring for and using your snow thrower.
- Follow the instructions under "Maintenance" and "Storage" sections of this manual.

PRODUCT SPECIFICATIONS

Gasoline Capacity and Type:	1.6 Quarts (1,5 Liters) Unleaded Regular only
Oil Type (API SG-SL):	SAE 30 (above 50°F) SAE 5W-30 or 10W-30 (32° to 50°F) SAE 5W-30 (below 32°F)
Oil Capacity:	16 Ounces (0,47 Liters)
Spark Plug:	F6RTC
Gap:	0.030" (0,762 mm)

TABLE OF CONTENTS

SAFETY RULES.....	2-3	MAINTENANCE.....	11-15
PRODUCT SPECIFICATIONS.....	3	STORAGE.....	16
CUSTOMER RESPONSIBILITIES.....	3	TROUBLESHOOTING.....	17
SAFETY AND INSTRUCTIONAL DECALS.....	4	REPAIR PARTS.....	18-26
SETUP.....	5-6	WARRANTY.....	30
OPERATION.....	7-11		

KNOW YOUR SNOW THROWER

READ THIS OWNER'S MANUAL AND ALL SAFETY RULES BEFORE OPERATING YOUR SNOW THROWER. Compare the illustrations with your snow thrower to familiarize yourself with the location of various controls and adjustments. Save this manual for future reference.

These symbols may appear on your snow thrower or in literature supplied with the product. Learn and understand their meaning.

IMPORTANT: Safety and instruction decals are located near areas of potential danger. Replace damaged decals.

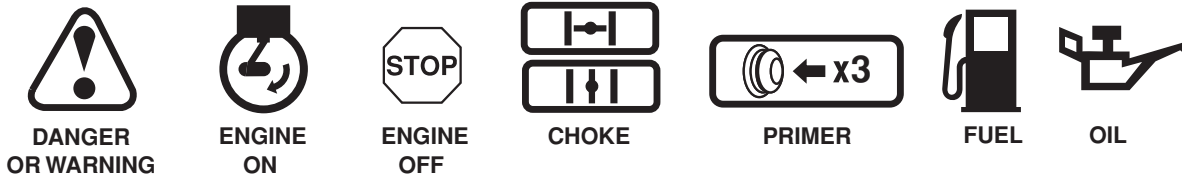

DANGER OR WARNING

ENGINE ON

ENGINE OFF

CHOKE

PRIMER

FUEL

OIL



READ AND FOLLOW ALL SAFETY INFORMATION AND INSTRUCTIONS BEFORE USE OF THIS PRODUCT. KEEP THESE INSTRUCTIONS FOR FUTURE REFERENCE.



IGNITION KEY. INSERT TO START AND RUN, PULL OUT TO STOP.



Setup

Loose Parts

Use the chart below to verify that all parts have been shipped.

Procedure	Description	Qty.	Use
1.	No parts required	–	Unfold the handle.
2.	Carriage bolts Flange nuts Washers Knob Chute Deflector	5 4 2 1 1 1	Install the discharge chute. Install the discharge chute. Install the discharge chute. Install the discharge chute.

1. Unfolding the Handle

Procedure

- Loosen the two handle knobs and pull out the two handle bolts until you can move the handle freely and rotate the handle to the operating position (Figure 2).

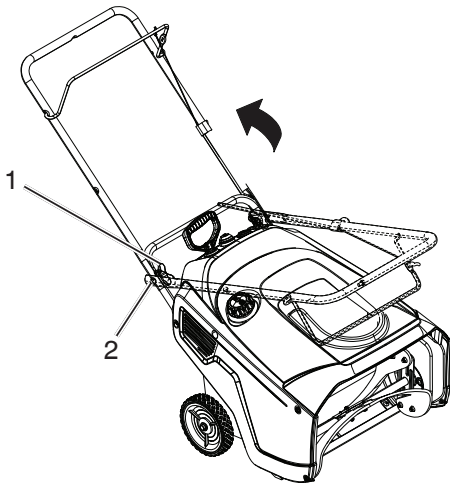

Figure 2

1. Handle knobs 2. Handle bolt

- Tighten the handle knobs until they are snug (Figure 3).

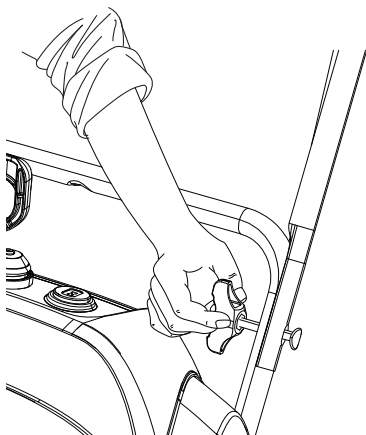

Figure 3

2. Installing the Discharge Chute

5	Carriage bolts
4	Flange nuts
2	Washers
1	Knob
1	Chute
1	Deflector

Procedure

Install the discharge chute as shown (Figure 4).

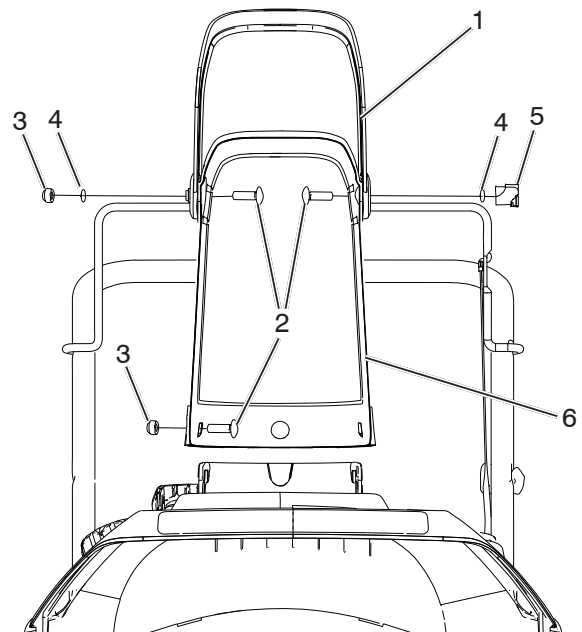

Figure 4

1. Deflector 4. Washer
2. Carriage bolts 5. Knob
3. Flange nuts 6. Discharge chute

IMPORTANT: Do not overtighten the flange nuts; otherwise you may damage the discharge chute.

3. Filling the Engine with Oil

ENGINE

See engine manual.

LUBRICATION

Use only high quality detergent oil rated with API service classification SG–SL. Select the oil's SAE viscosity grade according to your expected operating temperature.

NOTE: Although multi-viscosity oils (5W30, 10W30 etc.) improve starting in cold weather, these multi-viscosity oils will result in increased oil consumption when used above 32°F. Check your engine oil level more frequently to avoid possible engine damage from running low on oil.

Change the oil after every 25 hours of operation or at least once a year if the snow thrower is not used for 25 hours in one year.

Check the crankcase oil level before starting the engine and after each five (5) hours of continuous use. Tighten oil fill cap / dipstick securely each time you check the oil level.

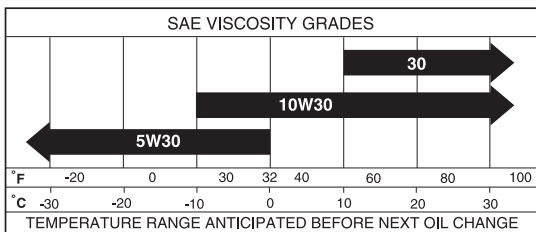

Figure 5

NOTE: 10W30 synthetic oil is acceptable for use in cold temperatures.

1. Move the snowthrower to a level surface.
2. Clean around the dipstick (Figure 6).

NOTE: Dipstick location may vary depending on engine type.

3. Remove either side mounted filler cap dipstick or high oil fill dipstick and wipe it clean.

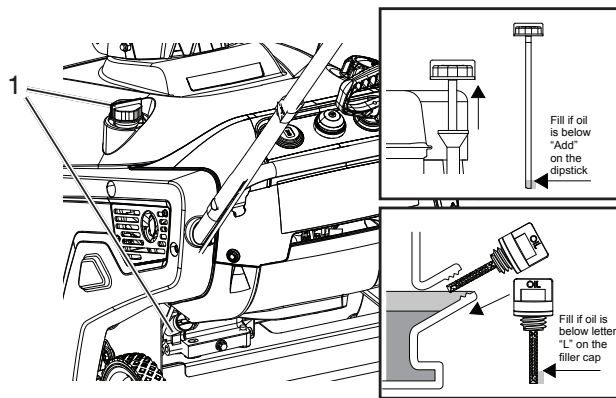

Figure 6

1. Oil filler cap/dipstick

4. Insert the dipstick into the filler neck and turn clockwise until fully seated. Then remove the dipstick by turning it counter-clockwise.
5. Fill oil to "FULL" on dipstick with the recommended oil.
6. Securely screw in the oil filler cap/dipstick.

Product Overview

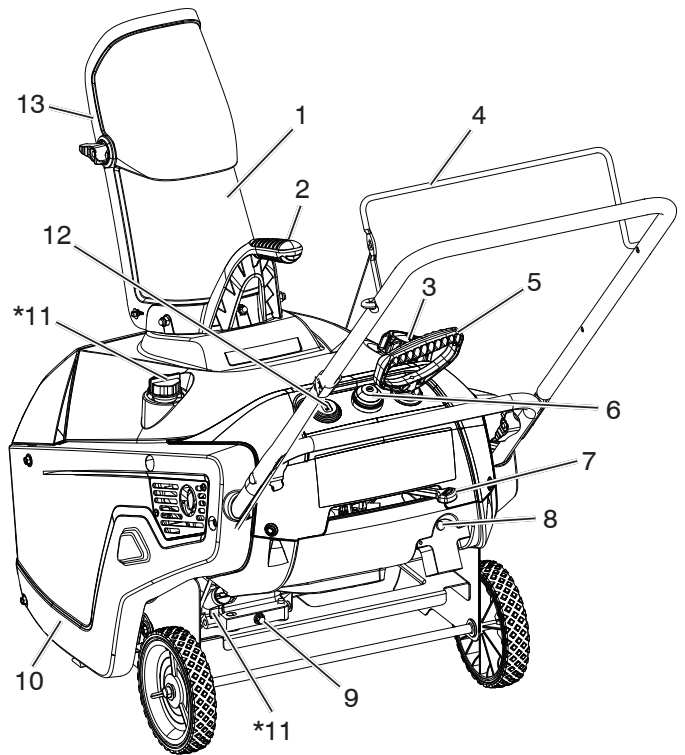



Figure 7

- | | |
|---------------------------|----------------------------|
| 1. Discharge chute | 8. Electric-start button |
| 2. Chute deflector handle | 9. Oil drain plug |
| 3. Fuel tank cap | 10. Drive belt cover |
| 4. Control bar | *11. Oil fill cap/dipstick |
| 5. Recoil start handle | 12. Ignition key |
| 6. Primer | 13. Chute deflector |
| 7. Choke lever | |

* Dipstick location may vary depending on engine type.

Operation

NOTE: Determine the left and right sides of the machine from the normal operating position.



- **Gasoline is extremely flammable and explosive. A fire or explosion from gasoline can burn you and others.**
- **To prevent a static charge from igniting the gasoline, place the container and/or snowthrower on the ground before filling, not in a vehicle or on an object.**
- **Fill the tank outdoors when the engine is cold. Wipe up spills.**
- **Do not handle gasoline when smoking or around an open flame or sparks.**
- **Store gasoline in an approved fuel container, out of the reach of children.**
- **Do not tip the snowthrower with fuel in the fuel tank.**



The operation of any snow thrower can result in foreign objects thrown into the eyes, which can result in severe eye damage. Always wear safety glasses or eye shields while operating your snow thrower or performing any adjustments or repairs. We recommend standard safety glasses or a wide vision safety mask worn over spectacles.

IMPORTANT: Know how to operate all controls before adding fuel or attempting to start the engine.

Filling the Fuel Tank

Fill the fuel tank with fresh unleaded gasoline, do not exceed 87 octane rating (Figure 8).

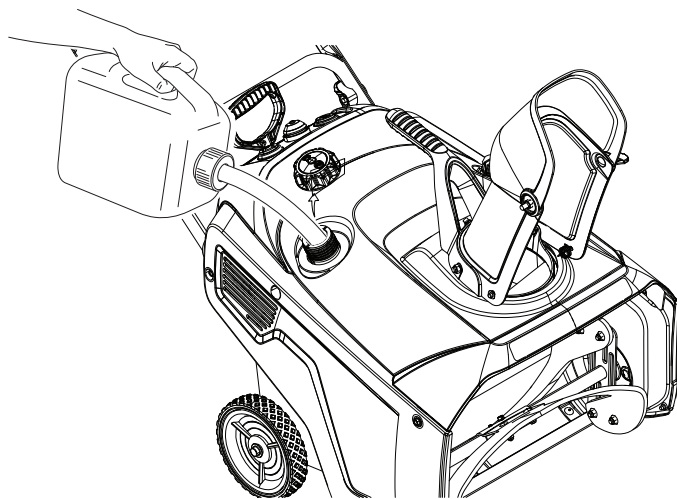

Figure 8

IMPORTANT: Do not add oil to the gasoline.

IMPORTANT: Do not use E85 blended fuels. This engine is not E20/E30/E85 compatible. Alternative fuels with high alcohol content can cause hard starting, poor engine performance, and may cause internal engine damage.

NOTE: For best results, purchase only the quantity of gasoline that you expect to use in 30 days. Otherwise, you may add fuel stabilizer to newly purchased gasoline to keep it fresh for up to 6 months.

Checking the Engine Oil Level

NOTE: 10W30 synthetic oil is acceptable for use in cold temperatures.

1. Move the snowthrower to a level surface.
2. Clean around the dipstick (Figure 9).

NOTE: Dipstick location may vary depending on engine type.

3. Remove either side mounted filler cap dipstick or high oil fill dipstick and wipe it clean.

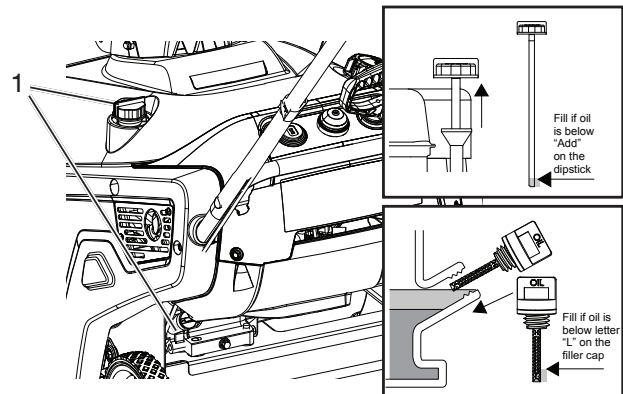

Figure 9

1. Oil filler cap/dipstick

4. Insert the dipstick into the filler neck and turn clockwise until fully seated. Then remove the dipstick by turning it counter-clockwise.
5. Fill oil to "FULL" on dipstick with the recommended oil.
6. Securely screw in the oil filler cap/dipstick.

NOTE: Running the engine with a low oil level can cause engine damage. Always check the engine oil before start up.

NOTE: Running the engine with too much oil may cause engine damage and excess smoke in the exhaust. Always check the engine oil level before start up.

Starting the Engine

1. Push key in (Figure 10).

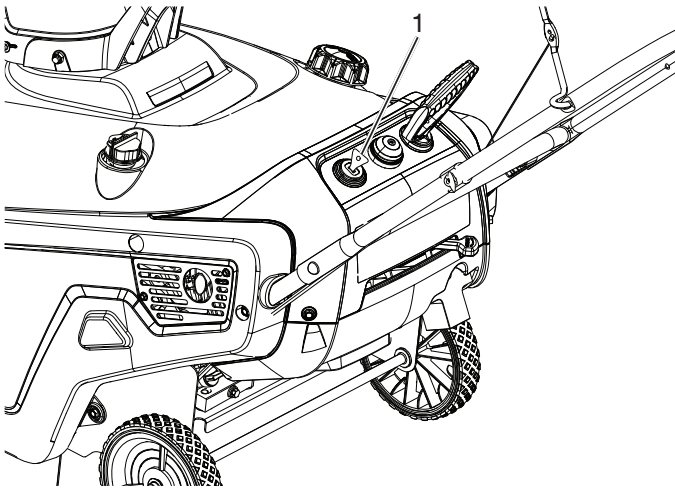

Figure 10

1. Key

2. Move choke lever to left position (Figure 11).

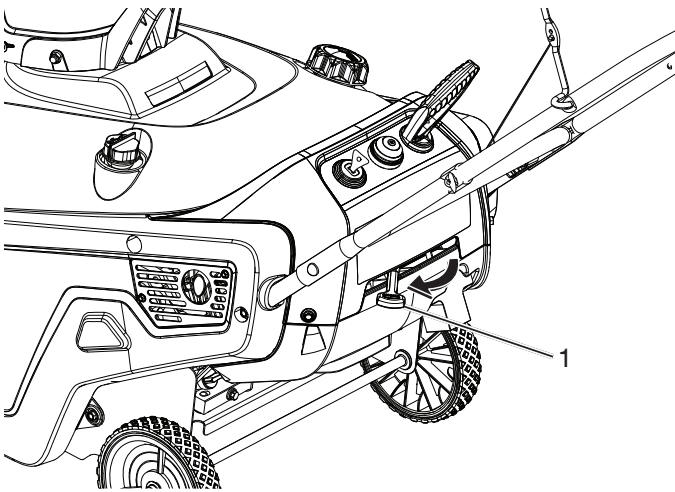

Figure 11

1. Choke lever

3. Firmly push in the primer 3 times with your thumb, holding the primer in a for a second before releasing it each time (Figure 12).

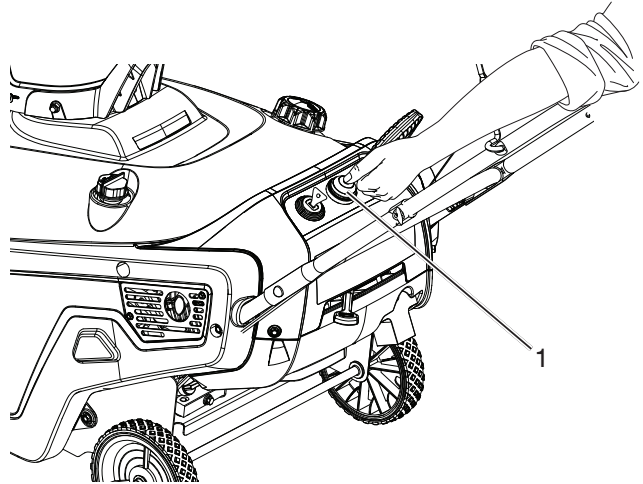

Figure 12

1. Primer

NOTE: Remove your glove when you push in the primer so that air cannot escape from the primer hole.

IMPORTANT: Do not use the primer or the choke if the engine has been running and is hot. Excessive priming may flood the engine and prevent it from starting.

4. Connect an extension cord to the snowthrower and plug the other end into a three-hole grounded 120 volt A.C. receptacle and push the electric-start button (Figure 13), or pull the recoil start handle (Figure 14).

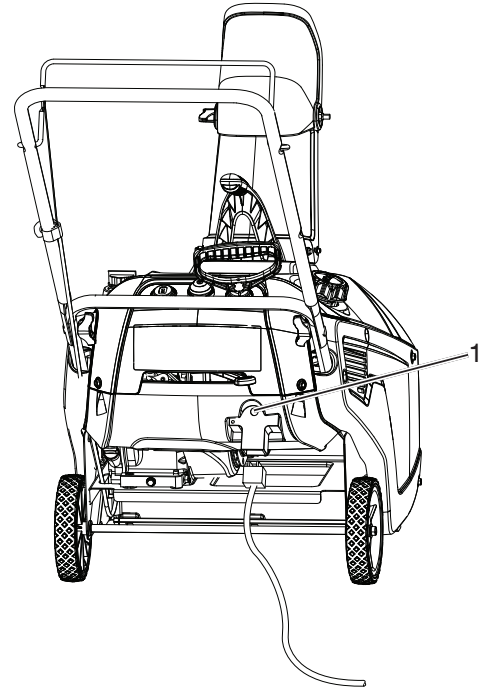

Figure 13

1. Electric start button

NOTE: Use only a UL-listed, 16-gauge extension cord recommended for outdoor use that is not longer than 50 feet (15 m).



The electrical cord can become damaged, causing a shock or fire.

Thoroughly inspect the electrical cord before plugging it into a power source. If the cord is damaged, do not use it to start the snowthrower. Replace or repair the damaged cord immediately. Contact an Authorized Service Dealer for assistance.



Figure 14

1. Recoil start handle

IMPORTANT: Run the electric starter no more than 10 times at intervals of 5 seconds on, then 5 seconds off. Running the electric starter extensively can overheat and damage it. If the engine does not start after this series of attempts, wait at least 40 minutes to allow the starter to cool before attempting to start it again. If the engine does not start after the second series of attempts, take the snowthrower to an Authorized Service Dealer for service.

NOTE: If you pull the recoil handle and feel no resistance, the starter may be frozen. Thaw out the starter before attempting to start the snowthrower.

5. While the engine is running, move the choke lever slowly to the left position (Figure 11).
6. Unplug the extension cord from the power source and the snowthrower (Figure 13).



Unplug the power cord whenever you are not starting the snowthrower.

Engaging the Auger Blades

To engage the auger blades, hold the control bar against the handle (Figure 15).



Figure 15

1. Control bar

Disengaging the Auger Blades

To disengage the auger blades, release the control bar (Figure 16).

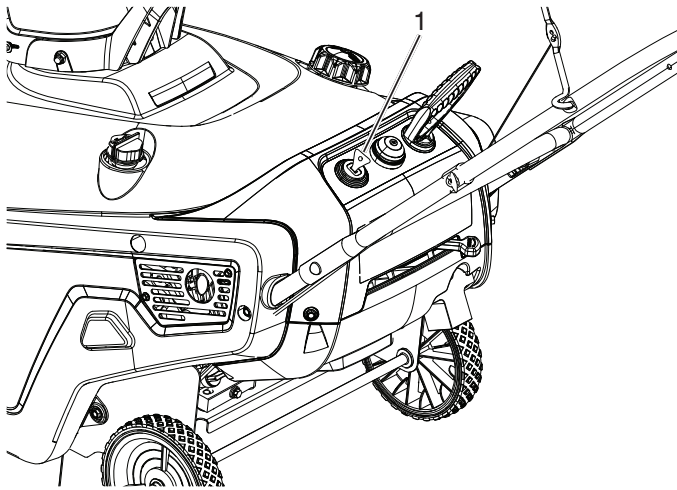

Figure 16

1. Control bar

Stopping the Engine

To stop the engine, pull key out (Figure 17).



1. Key

Figure 17

Adjusting the Discharge Chute and Chute Deflector

To adjust the discharge chute, move deflector chute handle left or right to desired position (Figure 18).

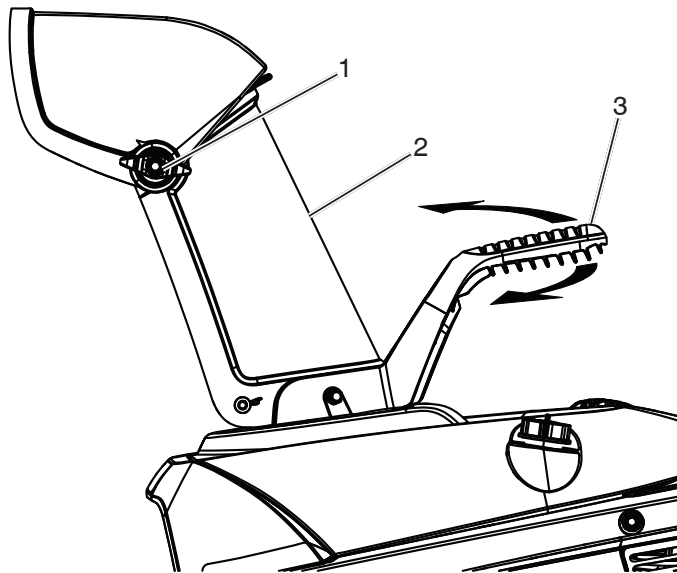

Figure 18

1. Chute deflector knob
2. Chute deflector
3. Chute handle

To raise or lower the angle of the chute deflector, loosen the chute deflector knob on the chute deflector and move the chute deflector up or down (Figure 18).

Clearing a Clogged Discharge Chute



Hand contact with the rotating auger blades inside the discharge chute is the most common cause of injury associated with snow throwers. Never use your hand to clean out the discharge chute.

To clear the chute:

1. SHUT THE ENGINE OFF!
2. Wait 10 seconds to be sure the auger blades have stopped rotating.
3. Always use a clearing tool at least 15 inches long, not your hands (Figure 19).



Figure 19

Preventing Freeze-up after Use

- Let the engine run for a few minutes to prevent moving parts from freezing. Stop the engine, wait for all moving parts to stop, and remove ice and snow from the snowthrower.
- Clean off any snow and ice from the base of the chute.
- Rotate the discharge chute left and right to free it from any ice buildup.
- With the ignition key in the Off position, pull the recoil starter handle several times or connect the electrical cord to a power source and the snowthrower and push the electric start button once to prevent the recoil starter and/or the electric starter from freezing up.
- In snowy and cold conditions, some controls and moving parts may freeze. Do not use excessive force when trying to operate frozen controls. If you have difficulty operating any control or part, start the engine and let it run for a few minutes.

Operating Tips



The auger blades can throw stones, toys, and other foreign objects and cause serious personal injury to the operator or to bystanders.

- Keep the area to be cleared free of all objects that the auger blades could pick up and throw.
- Keep all children and pets away from the area of operation.
- Do not operate snow thrower if weather conditions impair visibility. Throwing snow during a heavy, windy snowstorm can blind you and be hazardous to the safe operation of the snow thrower.

- The best time to remove snow is the early morning. At this time the snow is usually dry and has not been exposed to the direct sun and warming temperatures.
- Slightly overlap each successive path to ensure all snow will be removed.
- Throw snow downwind whenever possible.
- For extremely heavy snow, reduce the width of snow removal by overlapping previous path and moving slowly.
- Keep engine clean and clear of snow during use. This will help air flow and extend engine life.
- After snow-throwing is completed, allow engine to run for a few minutes to melt snow and ice off the engine.
- Clean the entire snow thrower thoroughly after each use and wipe dry so it is ready for next use.

Maintenance

NOTE: Determine the left and right sides of the machine from the normal operating position.

MAINTENANCE SCHEDULE		SERVICE INTERVALS				SERVICE DATES							
		BEFORE EACH USE	AFTER EACH USE	EVERY 25 HOURS OR EVERY SEASON	BEFORE STORAGE								
FILL IN DATES AS YOU COMPLETE REGULAR SERVICE													
T H R O W E R	Check for Loose Fasteners	✓			✓								
	Clean / Inspect Snow Thrower		✓		✓								
	Check / Replace V-Belts			✓									
	Lubrication Chart			✓	✓								
E N G I N E	Check Engine Oil Level	✓											
	Change Engine Oil			✓									
	Inspect Muffler			✓									
	Check / Replace Spark Plug			✓									
	Empty Fuel Tank				✓								

Adjusting the Control Cable

Checking the Control Cable

Release the control bar to remove the slack in the control cable (Figure 20).

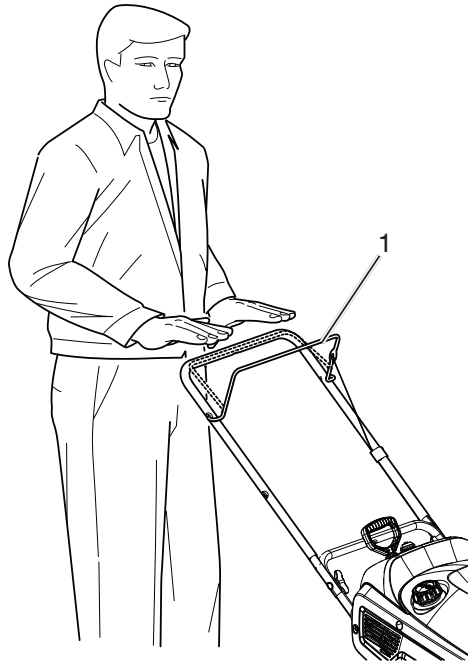

Figure 20

- 1. Control bar

IMPORTANT: The control cable must contain some slack when you disengage the control bar for the auger blades to stop properly.

NOTE: You may need to adjust the control cable from position 1 (default) to position 2 if you notice belt slip when the control bar is engaged.

NOTE: If the control cable is adjusted to position 2, ensure that the auger stops properly when the control bar is released

Adjusting the Control Cable

1. With the control bar disengaged, unhook and move the control cable to the highest position. (Figure 21).

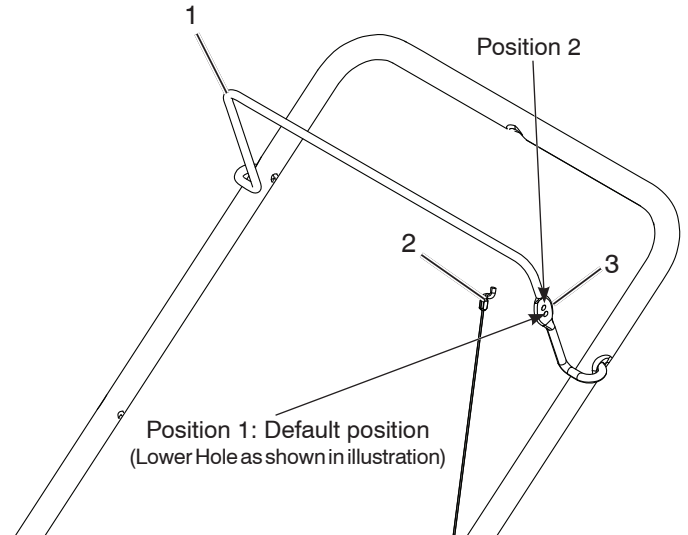

Figure 21

- 1. Control bar
- 2. Adjuster link
- 3. Cable positions

Inspecting the Auger Blades

Before each session, inspect the auger blades for wear. When a auger blade edge has worn down have an Authorized Service Dealer replace the auger blades and the scraper (Figure 22).

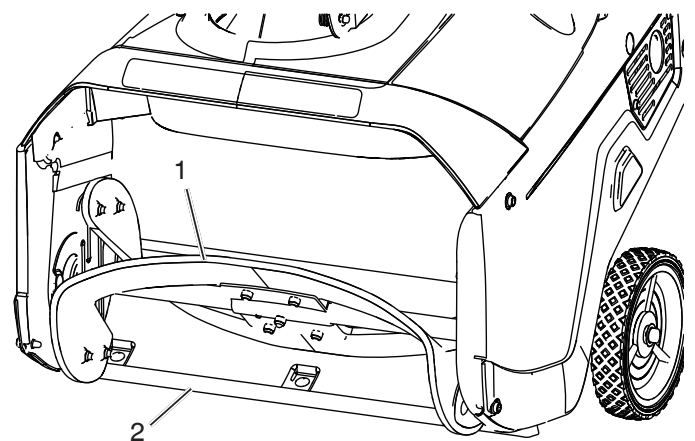

Figure 22

- 1. Auger blades
- 2. Scraper

Changing the Engine Oil

Run the engine a few minutes before changing the oil to warm it. Warm oil flows better and carries more contaminants.



The engine oil will be hot. Avoid skin contact with the used engine oil.

1. Move snowthrower to a level surface.
2. Run snowthrower until all fuel has been depleted.
3. Remove ignition key.

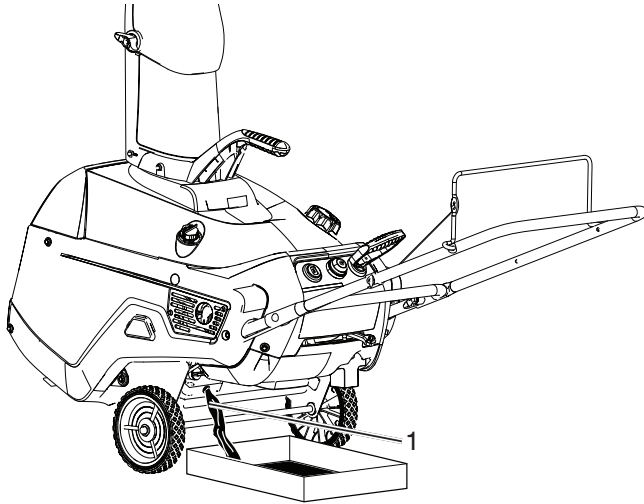

Figure 23

1. Oil drain plug

4. Place an oil drain pan under the oil drain plug, remove the oil drain plug, and tip the snowthrower backward and drain the used oil in the oil drain pan (Figure 23).
5. After draining the used oil, return the snowthrower to the operating position.
6. Install the oil drain plug and torque to 145-150 in-lbs (17 N-m).

NOTE: Dipstick location may vary depending on engine type.

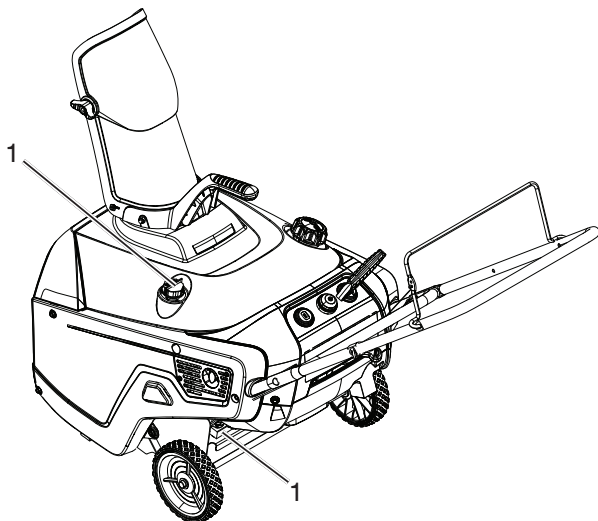

Figure 24

1. Oil fill cap/dipstick

7. Clean around the oil filler cap/dipstick (Figure 24).
8. Unscrew the oil fill cap/dipstick and remove it (Figure 24).
9. With the snowthrower in the operating position, carefully pour oil into the oil fill hole until "Full" on the fill cap/dipstick line (Figure 26).

Max fill: 18 oz. (0.5 l), type: automotive detergent oil with an API service classification of SJ, SL, or higher.

Use Figure 25 below to select the best oil viscosity for the outdoor temperature range expected:

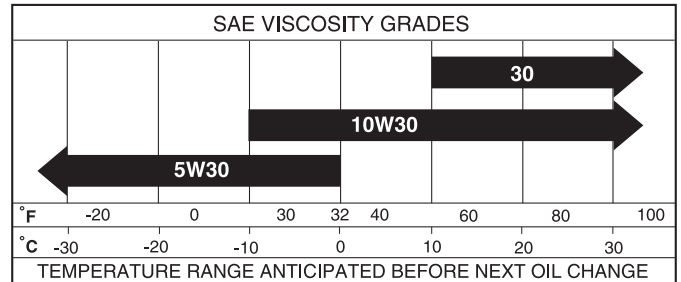

Figure 25

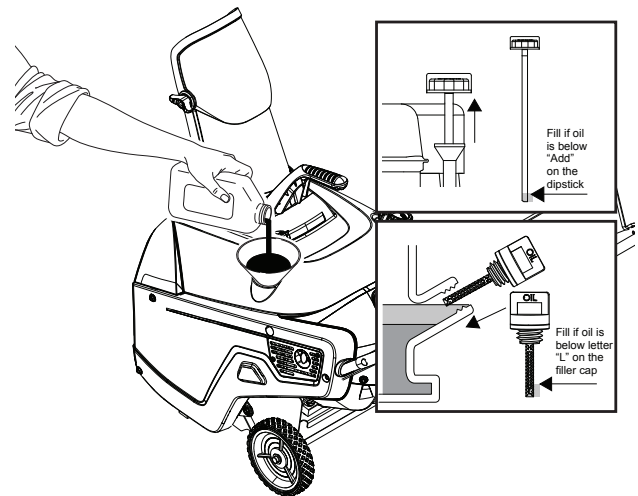

Figure 26

NOTE: 10W30 synthetic oil is acceptable for use in cold temperatures.

10. Screw in the oil fill cap/dipstick and hand tighten it securely.
11. Wipe up any spilled oil.
12. Dispose of the used oil properly at a local recycling center.

Servicing the Spark Plug

Use a NGK BPR6ES, Champion RN9YC, or BOSCH WR6DC spark plug or equivalent.

1. Stop the engine and wait for all moving parts to stop.
2. Rotate the discharge chute so that it faces forward.
3. Remove the discharge chute, the discharge chute handle by removing the three carriage bolts and flange nuts (Figure 27).

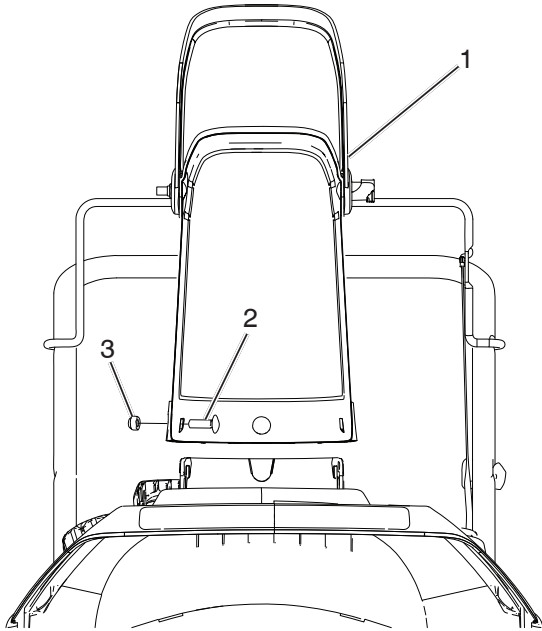

Figure 27

1. Discharge chute
2. Carriage bolts
3. Flange nuts

4. Remove the six screws that secure the shroud assembly (Figure 28).

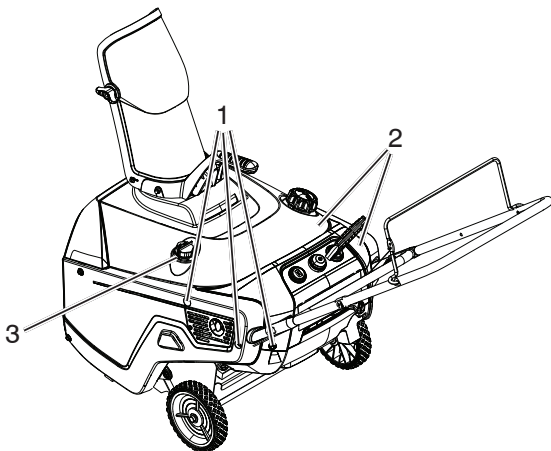

Figure 28

1. Screw
2. Shroud assembly
3. Oil fill cap

5. Remove the oil fill cap.
6. Remove the shroud assembly (Figure 28).
7. Install the oil fill cap.
8. Disconnect the spark plug wire from the spark plug (Figure 29).
9. Clean around the spark plug.
10. Remove the spark plug from the cylinder head.

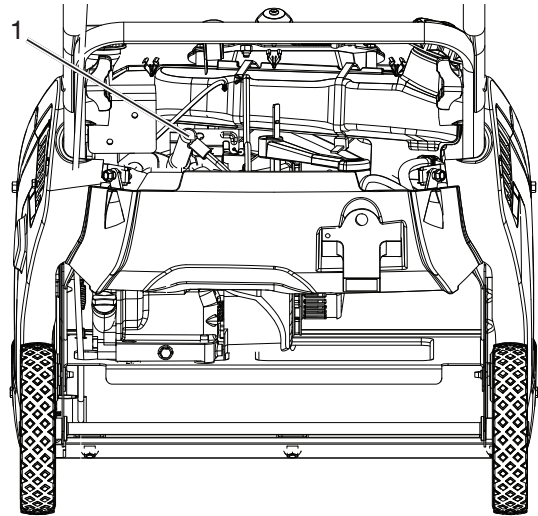

Figure 29

1. Spark plug wire

IMPORTANT: Replace a cracked, fouled, or dirty spark plug. Do not clean the electrodes because grit entering the cylinder can damage the engine.

11. Set the gap on the plug to 0.030 inch (0.76 mm) (Figure 30).

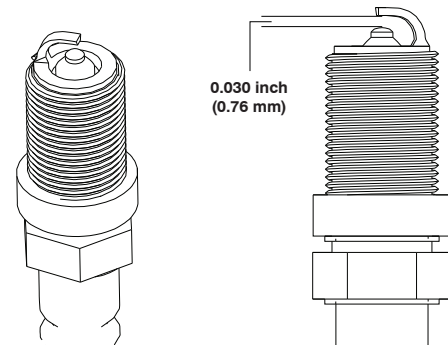

Figure 30

12. Install the spark plug and torque it to 20–22 ft-lb (27–30 N-m).
13. Connect the spark plug wire to the spark plug (Figure 29).
14. Remove the oil fill cap.
15. Install the shroud with the screws removed in step 4 (Figure 28).

NOTE: Ensure that the shroud assembly fits together in the side grooves.

16. Install the oil fill cap.
17. Install the discharge chute, and the discharge chute handle onto the snowthrower using the hardware removed in step 3 (Figure 27).

Replacing the Drive Belt

If drive belt becomes worn, oil-soaked, excessively cracked, frayed, or otherwise damaged, replace the belt.

1. Remove the drive side cover by removing the six screws as shown in (Figure 31).

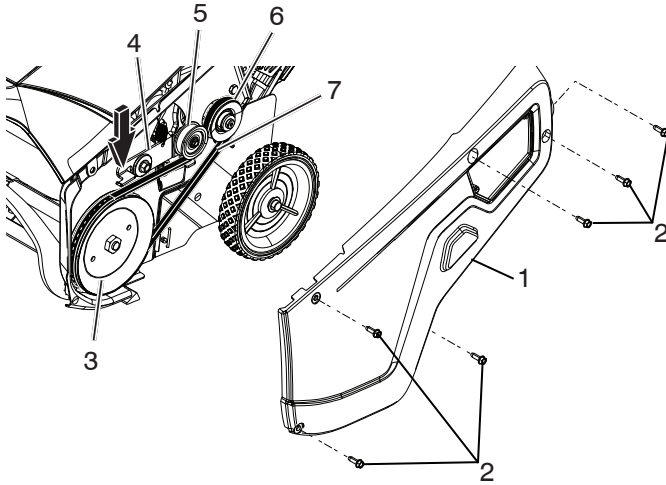

Figure 31

- | | |
|---------------------|------------------|
| 1. Drive side cover | 5. Idler pulley |
| 2. Screw | 6. Engine pulley |
| 3. Drive pulley | 7. Drive belt |
| 4. Idler arm | |

2. Press down on front of idler arm to release the belt tension (Figure 31).
3. Remove the drive belt from the drive pulley (Figure 31).

4. Install the new drive belt, routing it as shown in (Figure 32).

NOTE: Route the new drive belt first around the engine pulley, then the idler pulley, and finally around the drive pulley while pressing down on the front of the idler arm. (Figure 32).

5. Install the drive side cover with the screws removed in step 1.

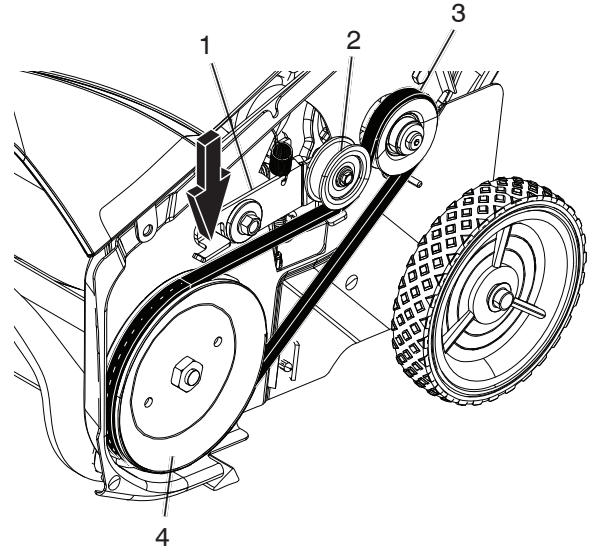

Figure 32

- | |
|------------------|
| 1. Idler arm |
| 2. Idler pulley |
| 3. Engine pulley |
| 4. Drive pulley |

NOTE: Ensure that the drive belt is properly adjusted and operating; refer to Checking the Control Cable and Adjusting the Control Cable in the Maintenance section of this manual.

Storage

Storing the Snowthrower

Immediately prepare your snow thrower for storage at the end of the season or if the unit will not be used for 30 days or more.



WARNING: Never store the snow thrower with gasoline in the tank inside a building where fumes may reach an open flame, spark or pilot light as on a furnace, water heater, clothes dryer or gas appliance. Allow the engine to cool before storing in any enclosure.

SNOW THROWER

When snow thrower is to be stored for a period of time, clean it thoroughly, remove all dirt, grease, leaves, etc. Store in a clean, dry area.

1. Clean entire snow thrower after each use.
2. Inspect and replace belts, if necessary (See "Replacing the Drive Belt" section of this manual).
3. Be sure that all nuts, bolts, screws, and pins are securely fastened. Inspect moving parts for damage, breakage and wear. Replace if necessary.
4. Touch up all rusted or chipped paint surfaces; sand lightly before painting.

FUEL SYSTEM

IMPORTANT: It is important to prevent gum deposits from forming in essential fuel system parts such as carburetor, fuel hose, or tank during storage. Also, alcohol blended fuels (called gasohol or using ethanol or methanol) can attract moisture which leads to separation and formation of acids during storage. Acidic gas can damage the fuel system of an engine while in storage.

- Empty the fuel tank by starting the engine and letting it run until the fuel lines and carburetor are empty.
- Never use engine or carburetor cleaner products in the fuel tank or permanent damage may occur.
- Use fresh fuel next season.

NOTE: Fuel stabilizer is an acceptable alternative in minimizing the formation of fuel gum deposits during storage. Add stabilizer to gasoline in fuel tank or storage container. Always follow the mix ratio found on stabilizer container. Run engine at least 10 minutes after adding stabilizer to allow the stabilizer to reach the carburetor. Do not empty the gas tank and carburetor if using fuel stabilizer.

ENGINE OIL

Drain oil (with engine warm) and replace with clean engine oil. (See "Changing the Engine Oil" section of this manual).

CYLINDER

1. Remove spark plug.
2. Pour one ounce (29 ml) of oil through spark plug hole into cylinder.
3. Pull recoil starter handle slowly a few times to distribute oil.
4. Replace with new spark plug.

OTHER

- Remove safety ignition key; store it in a safe place.
- Do not store gasoline from one season to another.
- Replace your gasoline can if your can starts to rust. Rust and/or dirt in your gasoline will cause problems.
- If possible, store your snow thrower indoors and cover it to protect it from dust and dirt.
- Cover your snow thrower with a suitable protective cover that does not retain moisture. Do not use plastic. Plastic cannot breathe, which allows condensation to form and will cause your snow thrower to rust.

IMPORTANT: Never cover snow thrower while engine/exhaust area is still warm.

Troubleshooting

See appropriate section in manual unless directed to an authorized service center/department.

PROBLEM	CAUSE	CORRECTION
Does not start	<ol style="list-style-type: none"> 1. Fuel shut-off valve (if so equipped) in OFF position. 2. Safety ignition key is not inserted. 3. Out of fuel. 4. Throttle in STOP position (or ON/OFF switch is OFF). 5. Choke in OFF position. 6. Primer not depressed. 7. Engine is flooded. 8. Spark plug wire is disconnected. 9. Bad spark plug. 10. Stale fuel. 11. Water in fuel. 	<ol style="list-style-type: none"> 1. Turn fuel shut-off valve to OPEN position. 2. Insert safety ignition key. 3. Fill fuel tank with fresh, clean gasoline. 4. Move throttle to FAST position (or ON/OFF switch to ON position). 5. Move to FULL position. 6. Prime as instructed in the Operation section of this manual. 7. Wait a few minutes before restarting, DO NOT prime. 8. Connect wire to spark plug. 9. Replace spark plug. 10. Empty fuel tank & carburetor, refill with fresh, clean gasoline. 11. Empty fuel tank & carburetor, refill with fresh, clean gasoline.
Loss of power	<ol style="list-style-type: none"> 1. Spark plug wire loose. 2. Throwing too much snow. 3. Fuel tank cap is covered with ice or snow. 4. Dirty or clogged muffler. 5. Improper cable length. 	<ol style="list-style-type: none"> 1. Reconnect spark plug wire. 2. Reduce speed and width of swath. 3. Remove ice and snow on and around fuel tank cap. 4. Clean or replace muffler. 5. Adjust cable.
Engine idles or runs roughly	<ol style="list-style-type: none"> 1. Choke is in FULL position. 2. Blockage in fuel line. 3. Stale fuel. 4. Water in fuel. 5. Carburetor is in need of adjustment or overhaul. 	<ol style="list-style-type: none"> 1. Move choke to OFF position. 2. Clean fuel line. 3. Empty fuel tank & carburetor, refill with fresh, clean gasoline. 4. Empty fuel tank & carburetor, refill with fresh, clean gasoline. 5. Contact an authorized service center/department.
Excessive vibration	<ol style="list-style-type: none"> 1. Loose parts or damaged augers or impeller. 	<ol style="list-style-type: none"> 1. Tighten all fasteners. Replace damaged parts. If vibration remains, contact an authorized service center/department.
Recoil starter is hard to pull	<ol style="list-style-type: none"> 1. Frozen recoil starter. 	<ol style="list-style-type: none"> 1. See "IF RECOIL STARTER HAS FROZEN" in the Operation section of this manual.
Loss of traction drive / slowing of drive speed	<ol style="list-style-type: none"> 1. Drive belt is worn. 2. Drive belt is off of pulley. 3. Auger blades worn. 	<ol style="list-style-type: none"> 1. Check / replace drive belt. 2. Check / reinstall drive belt. 3. Contact an authorized service center/department.
Loss of snow discharge or slowing of snow discharge	<ol style="list-style-type: none"> 1. Auger belt is off of pulley. 2. Auger belt is worn. 3. Clogged discharge chute. 4. Augers / impeller jammed. 	<ol style="list-style-type: none"> 1. Check / reinstall auger belt. 2. Check / replace auger belt. 3. Clean snow chute. 4. Remove debris or foreign object from augers / impeller.

REPAIR PARTS SNOW THROWER - - MODEL NUMBER PR621 (96188000100)

CHUTE ASSEMBLY

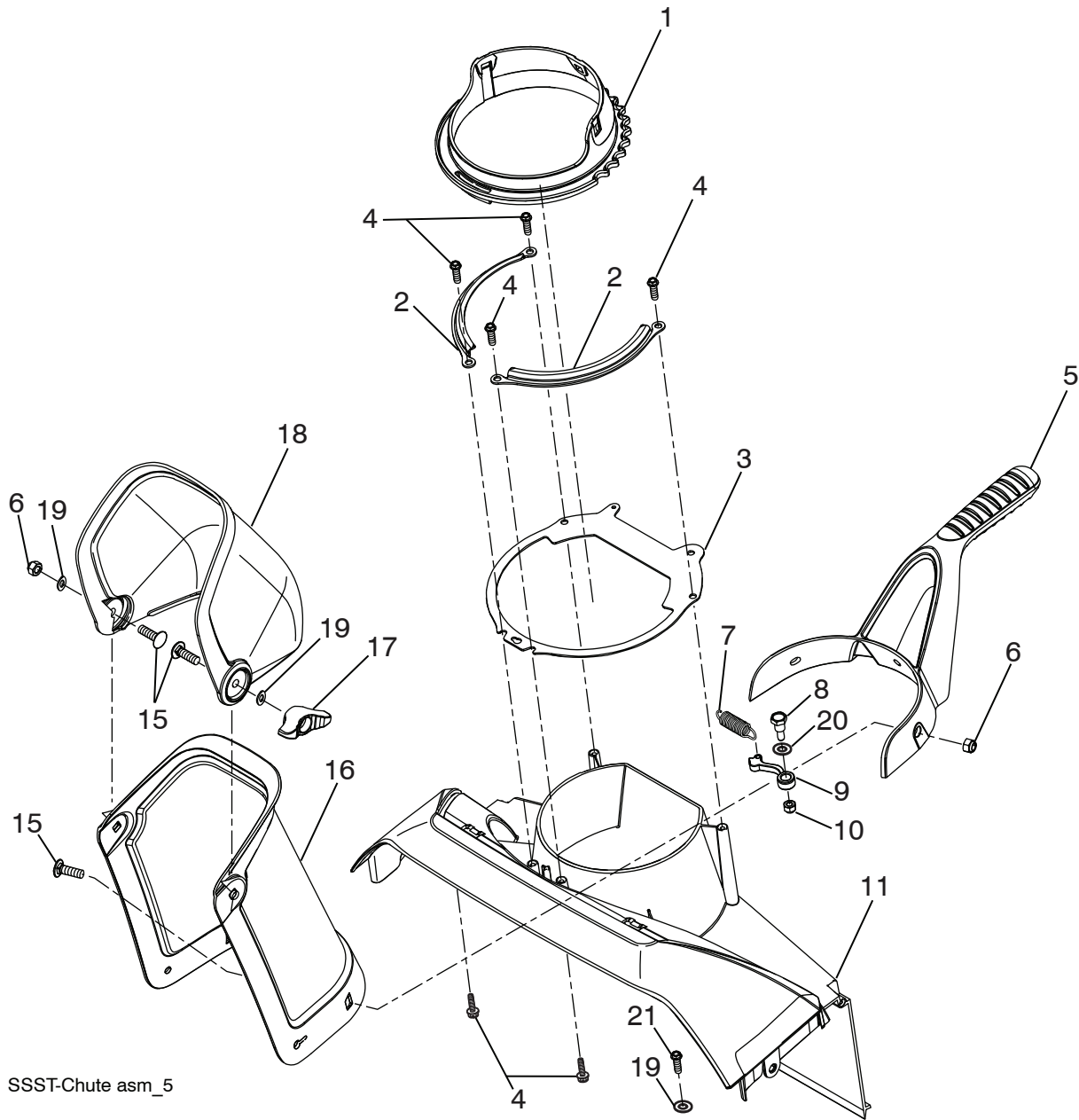

SSST-Chute asm_5

NOTE: All component dimensions given in U.S. inches. 1 inch = 25.4 mm
IMPORTANT: Use only Original Equipment Manufacturer (O.E.M.) replacement parts.
Failure to do so could be hazardous, damage your snow thrower and void your warranty.

**REPAIR PARTS SNOW THROWER - - MODEL NUMBER PR621 (96188000100)
CHUTE ASSEMBLY**

KEY NO.	PART NO.	QTY	DESCRIPTION
1	434877	1	CHUTE.RATCHETING.PLASTIC.W/GRV
2	434876X431	2	PLATE.CHUTE.RETAINER
3	434875X431	1	PLATE.CHUTE.BASE
4	17411312	6	BOLT.HEX.WSH.HD.13-16 X 3/4
5	434885X428	1	HANDLE.CHUTE.MS428
6	73970500	4	NUT.LOCK.HX.W/INS 5/16-18 UNC PL
7	434879	1	SPRING.RATCHET.ARM
8	81328	1	BOLT.SHOULDER.1/4-20 UNC X .94
9	434878	1	ARM.CHUTE.RATCHET
10	132004	1	HEX.NUT.1/4-20 NYLON LOCKING
11	435980X428	1	PLENUM
15	437318	5	CARRIAGE.BOLT
16	434884X428	1	CHUTE
17	189713X428	2	HANDLE.KNOB
18	434886X428	1	DEFLECTOR.CHUTE
19	19131316	3	WASHER
20	19132416	1	WASHER.RATCHET.PAWL
21	428867	1	BOLT

NOTE: All component dimensions given in U.S. inches. 1 inch = 25.4 mm
IMPORTANT: Use only Original Equipment Manufacturer (O.E.M.) replacement parts.
 Failure to do so could be hazardous, damage your snow thrower and void your warranty.

REPAIR PARTS SNOW THROWER - - MODEL NUMBER PR621 (96188000100)
HANDLE ASSEMBLY

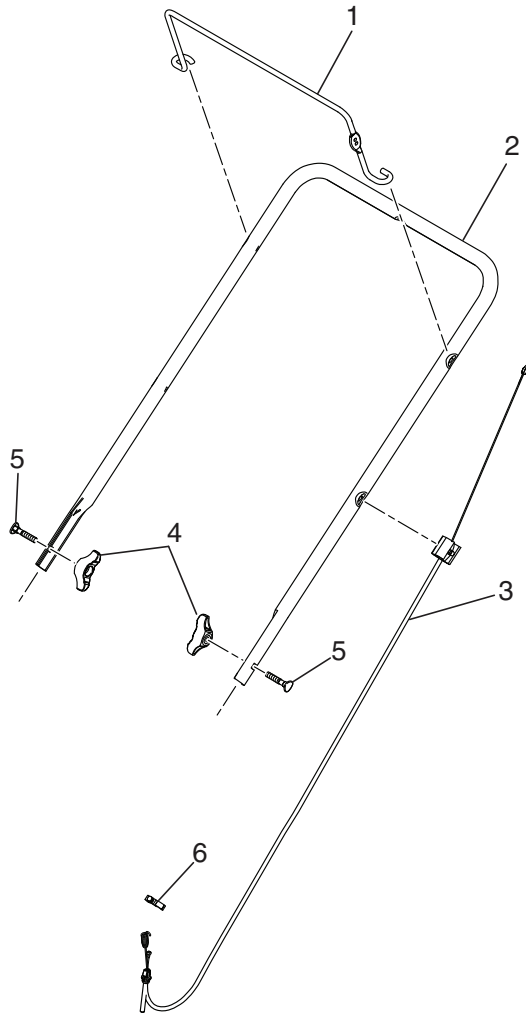

SSST-Handle asm_1

KEY NO.	PART NO.	QTY	DESCRIPTION
1	434805X431	1	BAIL.HANDLE.PAINT.MS431
2	434786X431	1	HANDLE.PNT.UPPER.SSST
3	434806	1	CONTROL.CABLE
4	189713X428	2	KNOB.HANDLE.BLACK
5	191574	2	BOLT.HANDLE.BLACK PATCHED
6	145006	1	CLIP.PUSH-IN.HINGED

NOTE: All component dimensions given in U.S. inches. 1 inch = 25.4 mm
IMPORTANT: Use only Original Equipment Manufacturer (O.E.M.) replacement parts.
 Failure to do so could be hazardous, damage your snow thrower and void your warranty.

REPAIR PARTS SNOW THROWER - - MODEL NUMBER PR621 (96188000100)

AUGER ASSEMBLY

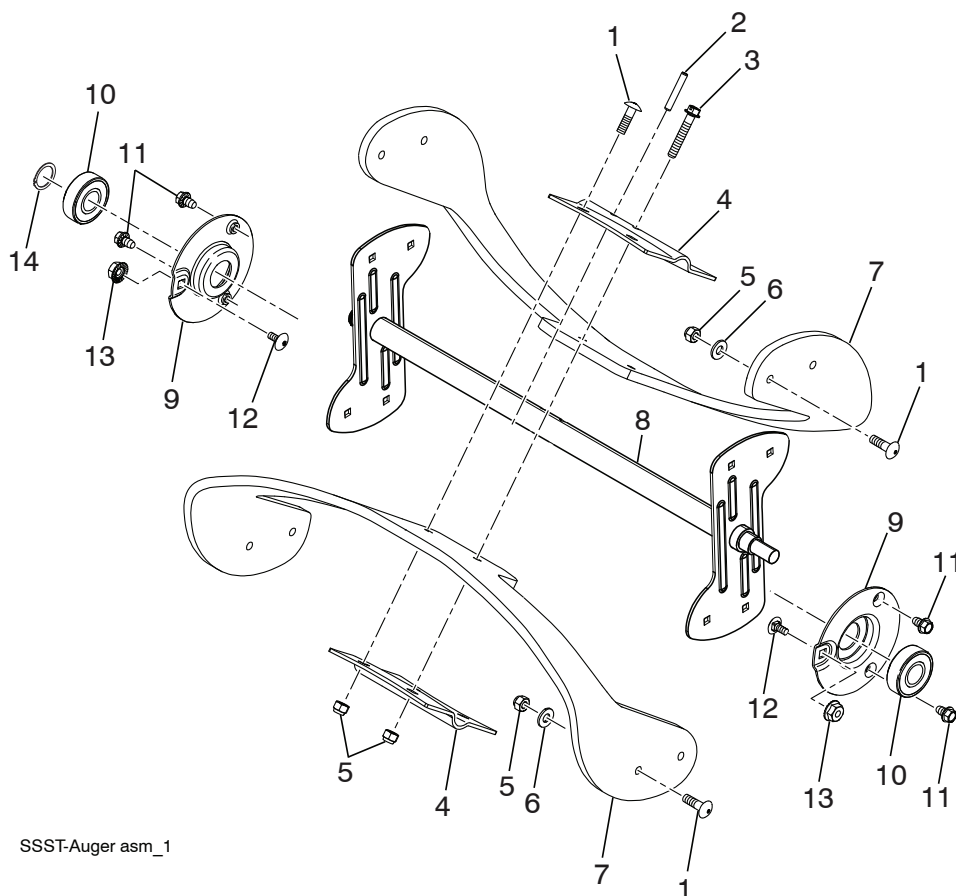

SSST-Auger asm_1

KEY NO.	PART NO.	QTY	DESCRIPTION
1	72110407	12	BOLT.CARRIAGE
2	5142H	1	PIN.ROLL.3/16 X 1-1/4
3	199687	1	BOLT.1/4-20.1.50"
4	434777X431	2	PLATE.CENTER.BLADE
5	132004	13	HEX.NUT.1/4-20 NYLON LOCKING
6	19091016	8	WASHER 9/32 X 5/8 X 16 GA.
7	435302	2	BLADE.AUGER
8	434862X428	1	WELDMENT.AUGER.ASM
9	434010X431	2	SUPPORT.BEARING.SSST.PNT
10	110485X	2	BEARING.BALL.MANDREL
11	17600406	4	SCREW.HEX.WASHEAD.1/4-20 X 3/8
12	72110404	2	BOLT.CARR.SS.1/4-20 UNC X 1/2.GR5
13	438130	2	WHIZ.LOCK.NUTS.BEARING CAPS
14	12000028	1	RETAINING.CLIP

NOTE: All component dimensions given in U.S. inches. 1 inch = 25.4 mm
IMPORTANT: Use only Original Equipment Manufacturer (O.E.M.) replacement parts. Failure to do so could be hazardous, damage your snow thrower and void your warranty.

REPAIR PARTS SNOW THROWER - - MODEL NUMBER PR621 (96188000100) SHROUD ASSEMBLY

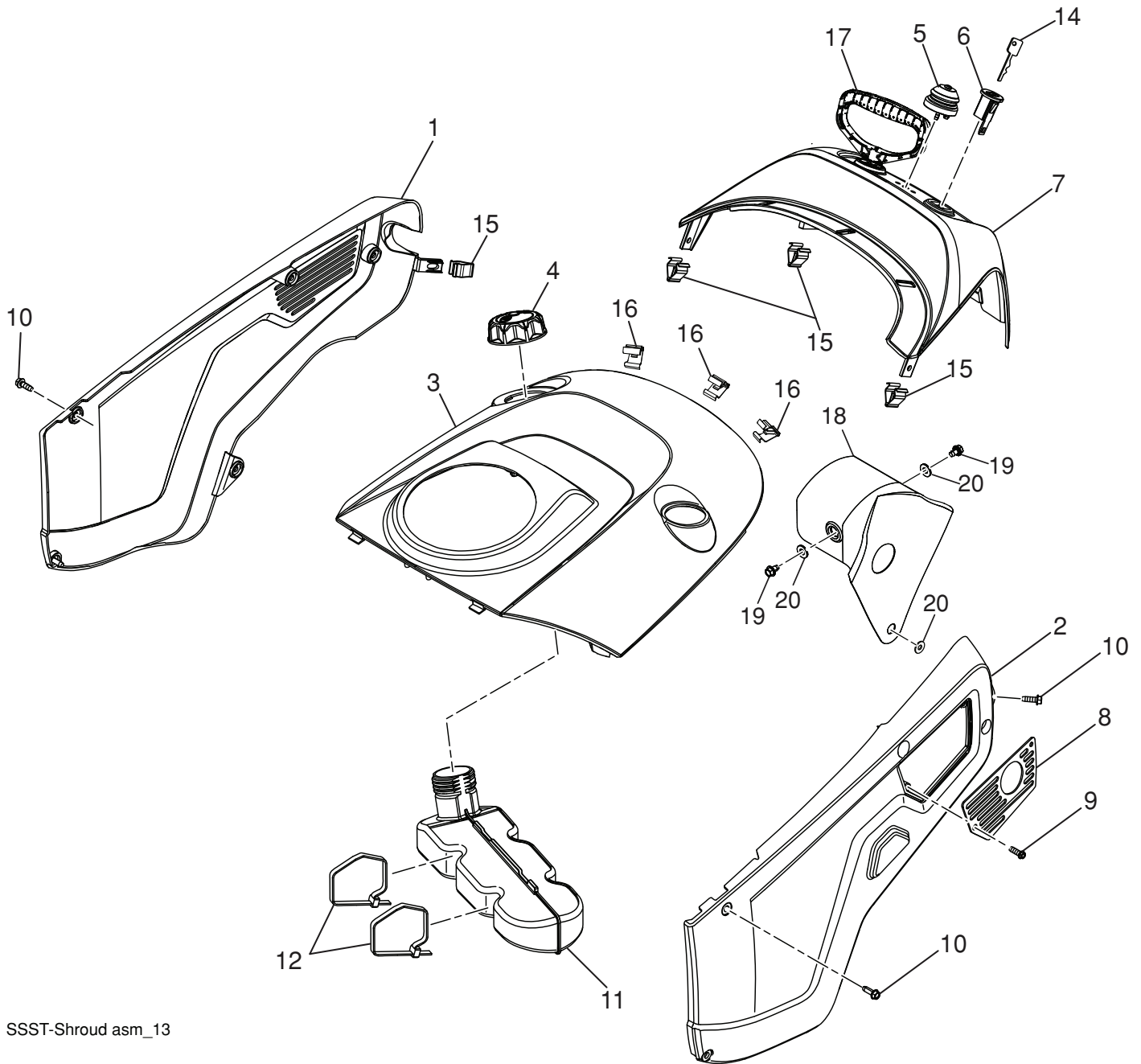

SSST-Shroud asm_13

NOTE: All component dimensions given in U.S. inches. 1 inch = 25.4 mm
IMPORTANT: Use only Original Equipment Manufacturer (O.E.M.) replacement parts.
Failure to do so could be hazardous, damage your snow thrower and void your warranty.

**REPAIR PARTS SNOW THROWER - - MODEL NUMBER PR621 (96188000100)
SHROUD ASSEMBLY**

KEY NO.	PART NO.	QTY	DESCRIPTION
1	435905X428	1	COVER.NON-DRIVE.SIDE.MS428
2	435904X428	1	COVER.DRIVE.SIDE.MS428
3	434883X421	1	TOP.COVER
4	430220	1	CAP.ASM.FUEL.2.25"FR.N/CB.E10
5	436235	1	BULB.PRIMER
6	435407	1	KEY HOUSING
7	434867X428	1	TOP.REAR.COVER
8	434873X431	1	PLATE.EXHAUST.PNT.
9	17411312	2	SCREW
10	17490412	12	SCREW.HEXWSH.THDROL.1/4-20X3/4
11	434880	1	TANK.FUEL.ASM.
12	146848	2	TIE.CABLE.24.5X.29.NYLON.WHITE
14	435409	2	KEY
15	196688	4	THREADED.CLIP
16	434868	3	CLIP.TRIM
17	436276	1	HDL.STARTER
18	437619	1	HEAT.SHIELD
19	438039	2	BOLT.M6X1X16MM
20	19091016	3	WASHER

NOTE: All component dimensions given in U.S. inches. 1 inch = 25.4 mm
IMPORTANT: Use only Original Equipment Manufacturer (O.E.M.) replacement parts.
 Failure to do so could be hazardous, damage your snow thrower and void your warranty.

REPAIR PARTS SNOW THROWER - - MODEL NUMBER PR621 (96188000100) FRAME ASSEMBLY

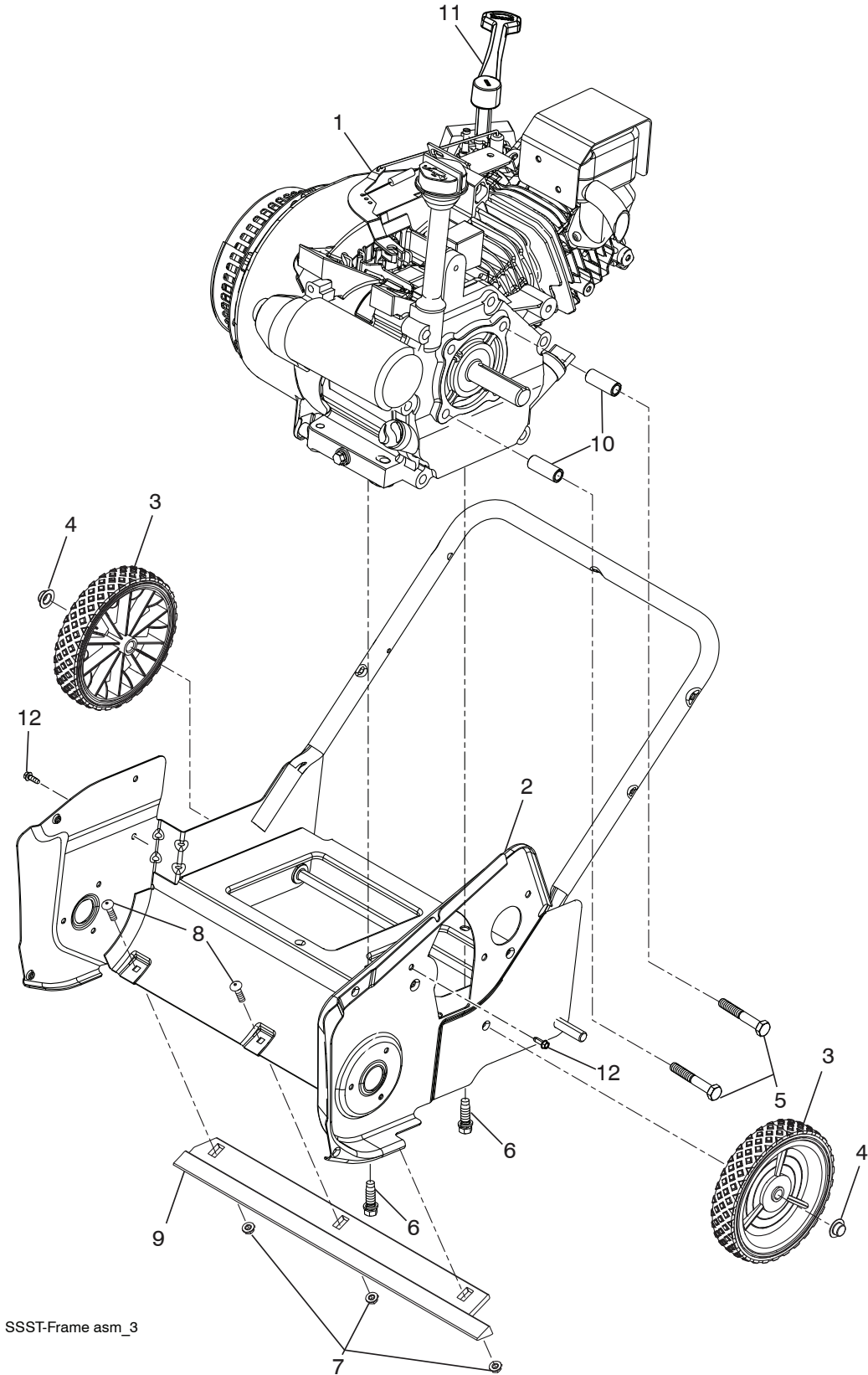

SSST-Frame asm_3

NOTE: All component dimensions given in U.S. inches. 1 inch = 25.4 mm
IMPORTANT: Use only Original Equipment Manufacturer (O.E.M.) replacement parts.
Failure to do so could be hazardous, damage your snow thrower and void your warranty.

**REPAIR PARTS SNOW THROWER - - MODEL NUMBER PR621 (96188000100)
 FRAME ASSEMBLY**

KEY NO.	PART NO.	QTY	DESCRIPTION
1	434856	1	LCT.ENGINE
2	434009X431	1	FRAME.WELDMENT
3	431937X428	2	WHEEL.7X1.5.DMD.GS.3SPK.MS428
4	435417	2	NUT.PUSH.AXLE.0.5IN
5	435578	2	SCREW. 5/16-24 X 2.00"HHCS
6	150406	2	BOLT.ENG. 3/8-16 X 1.280
7	191730	3	NUT.HEX.FLANGE.1/4-20.CTR.LOCK
8	72140405	3	BOLT.RDHD.SQNK.1/4-20 UNC X 5/8
9	435535	1	PLATE.SCRAPER
10	434857	2	SPACER.ENGINE
11	434874	1	LEVER.CHOKE
12	17411312	2	BOLT

NOTE: All component dimensions given in U.S. inches. 1 inch = 25.4 mm
IMPORTANT: Use only Original Equipment Manufacturer (O.E.M.) replacement parts.
 Failure to do so could be hazardous, damage your snow thrower and void your warranty.

REPAIR PARTS SNOW THROWER - - MODEL NUMBER PR621 (96188000100)

DRIVE ASSEMBLY

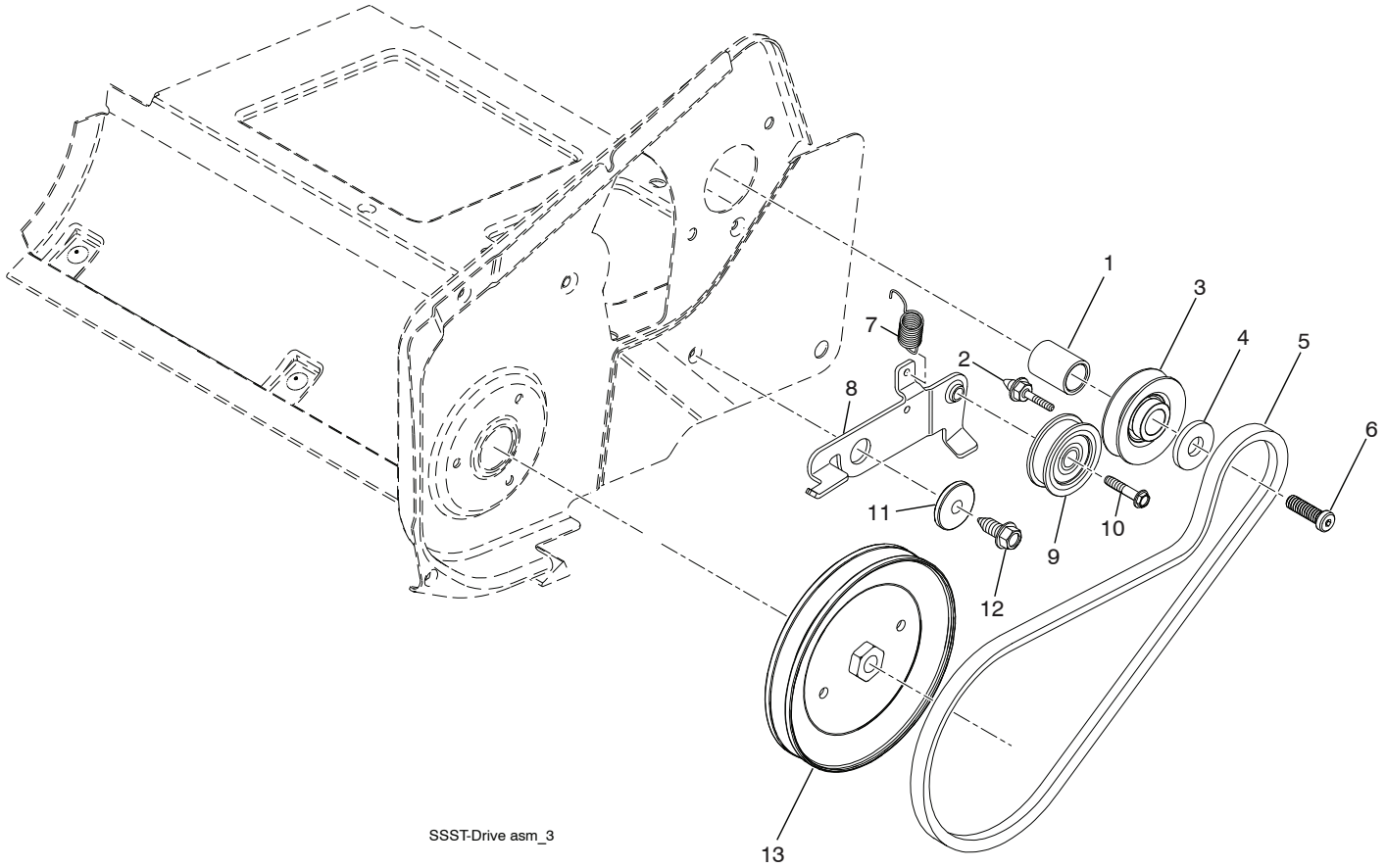

KEY NO.	PART NO.	QTY	DESCRIPTION
1	434860	1	SPACER.ENGINE.CRANK
2	434502	1	KEEPER.ENGINE.BELT
3	426490	1	PULLEY.ENG.TRACTION.3/4
4	851074	1	WASHER.HARDEN
5	437261	1	BELT-V.TRACTION
6	430817	1	SCREW.CAPSCHD.3/8-24 X 1.25
7	434859	1	SPRING.IDLER.PULLEY.RETURN
8	434848X431	1	ARM.IDLER.PNT.MS431
9	166043	1	PULLEY.IDLER.BACKSIDE
10	17060620	1	SCREW.HXWH.THDR.1/4-20X1-1/4
11	199092	1	SPACER.RETAINER
12	17060620	1	SCREW.3/8-16X1.SMGML.TAP/R.BLK
13	435383	1	PULLEY.DRIVEN
--	436414	1	OWNER'S.MANUAL.ENGLISH/FRENCH

NOTE: All component dimensions given in U.S. inches. 1 inch = 25.4 mm
IMPORTANT: Use only Original Equipment Manufacturer (O.E.M.) replacement parts. Failure to do so could be hazardous, damage your snow thrower and void your warranty.

SERVICE NOTES

REPAIR PARTS SNOW THROWER - - MODEL NUMBER PR621 (96188000100)
ENGINE, LCT **COMPLETE ENGINE-434856**

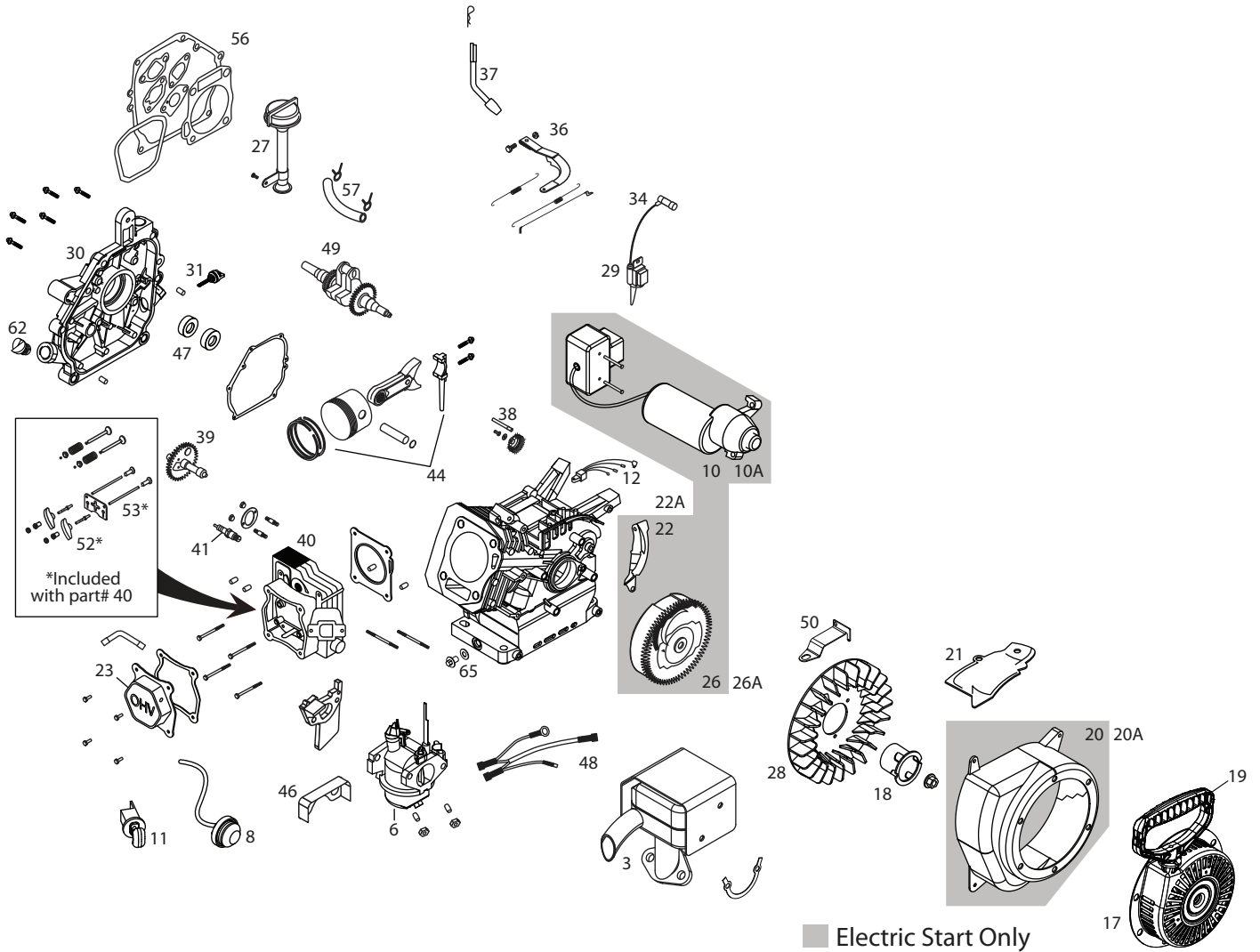

REPAIR PARTS SNOW THROWER - - MODEL NUMBER PR621 (96188000100)
ENGINE, LCT **COMPLETE ENGINE-434856**

KEY NO.	PART NO.	DESCRIPTION	KEY NO.	PART NO.	DESCRIPTION
3	437121	SNOW MUFFLER ASSY	26A	420585	MANUAL START FLYWHEEL ASSY (IF EQUIPPED)
6	437122	SNOW CARBURETOR ASSY	27	424969	HIGH OIL FILL TUBE ASSY
8	437123	FUEL PRIMER BULB WITH HOSE	28	420586	FLYWHEEL FAN
10	437124	ELECTRIC STARTER ASSY (IF EQUIPPED)	29	420595	IGNITION COIL ASSY
10A	437125	EUROPEAN 230V ELECTRIC STARTER ASSY (IF EQUIPPED)	30	420606	CRANKCASE COVER ASSY
11	424954	KEY SWITCH ASSY	31	420961	BLACK OIL DIPSTICK
12	424955	CDI BOX	34	436966	SPARK PLUG BOOT
17	436967	SNOW RECOIL STARTER ASSY	36	420601	GOVERNOR ARM ASSY
18	436968	STARTER CUP SMALL	37	420602	GOVERNOR SHAFT
19	424968	SNOW STARTER GRIP	38	429646	GOVERNOR GEAR ASSY
20	424971	BLOWER HOUSING ASSEMBLY ELECTRIC START SNOW (BLACK) (IF EQUIPPED)	39	420584	CAMSHAFT
20A	429230	BLOWER HOUSING ASSEMBLY MANUAL START -SNOW (BLACK) (IF EQUIPPED)	40	420578	CYLINDER HEAD ASSY
21	424973	SHIELD, CYLINDER	41	424939	SPARK PLUG
22	424975	SHIELD, FLYWHEEL-ELECTRIC START (IF EQUIPPED)	44	420582	PISTON AND ROD ASSY
22A	429596	SHIELD, FLYWHEEL-MANUAL START (IF EQUIPPED)	46	429260	VAPOR SHIELD
23	420580	VALVE COVER	47	429599	SEAL KIT
26	429235	ELECTRIC START FLYWHEEL ASSY (IF EQUIPPED)	48	437967	WIRE HARNESS
			49	429600	CRANKSHAFT
			50	429259	SPEED CONTROL BRACKET
			52	429691	ROCKER ARM KIT
			53	420579	PUSH ROD KIT
			54	436567	CYLINDER ASSEMBLY
			56	429601	GASKET KIT
			57	438014	FUEL HOSE KIT
			62	435495	NON-REMOVABLE OIL PLUG
			65	435495	OIL DRAIN PLUG KIT

LIMITED WARRANTY

The Manufacturer warrants to the original consumer purchaser that this product as manufactured is free from defects in materials and workmanship. For a period of two (2) years from date of purchase by the original consumer purchaser, we will repair or replace, at our option, without charge for parts or labor incurred in replacing parts, any part which we find to be defective due to materials or workmanship. This Warranty is subject to the following limitations and exclusions.

1. This warranty does not apply to the engine, transaxle/transmission components, battery (except as noted below) or components parts thereof. Please refer to the applicable manufacturer's warranty on these items.
2. Transportation charges for the movement of any power equipment unit or attachment are the responsibility of the purchaser. Transportation charges for any parts submitted for replacement under this warranty must be paid by the purchaser unless such return is requested by the manufacturer.
3. Battery Warranty: On products equipped with a Battery, we will replace, without charge to you, any battery which we find to be defective in manufacture, during the first ninety (90) days of ownership. After ninety (90) days, we will exchange the Battery, charging you 1/12 of the price of a new Battery for each full month from the date of the original sale. Battery must be maintained in accordance with the instructions furnished.
4. The Warranty period for any products used for rental or commercial purposes is limited to 90 days from the date of original purchase.
5. This Warranty applies only to products which have been properly assembled, adjusted, operated, and maintained in accordance with the instructions furnished. This Warranty does not apply to any product which has been subjected to alteration, misuse, abuse, improper assembly or installation, delivery damage, or to normal wear of the product.
6. Exclusions: Excluded from this Warranty are belts, blades, blade adapters, normal wear, normal adjustments, standard hardware and normal maintenance.
7. In the event you have a claim under this Warranty, you must return the product to an authorized service dealer.

Should you have any unanswered questions concerning this Warranty, please contact:

Poulan Pro
Outdoor Products Customer Service Dept.
9335 Harris Corners Parkway
Charlotte, NC 28269 USA

In Canada contact:
Poulan Pro
5855 Terry Fox Way
Mississauga, Ontario
L5V 3E4

giving the model number, serial number and date of purchase of your product and the name and address of the authorized dealer from whom it was purchased.

THIS WARRANTY DOES NOT APPLY TO INCIDENTAL OR CONSEQUENTIAL DAMAGES AND ANY IMPLIED WARRANTIES ARE LIMITED TO THE SAME TIME PERIODS STATED HEREIN FOR OUR EXPRESSED WARRANTIES. Some areas do not allow the limitation of consequential damages or limitations of how long an implied Warranty may last, so the above limitations or exclusions may not apply to you. This Warranty gives you specific legal rights, and you may have other rights which vary from locale to locale.

This is a limited Warranty within the meaning of that term as defined in the Magnuson-Moss Act of 1975.

Poulan PRO